

# For AR-15 and Compatible Rifle

## Disclaimer

### Limited Warranty

### Installation Instructions

#### **INSTALLATION WARNING:**

Failure to properly adjust both locking set screws and ensure proper fit with the safety selector could result in an unsafe firearm.

Carefully read and follow the instructions. Contact us or a licensed gunsmith for assistance.

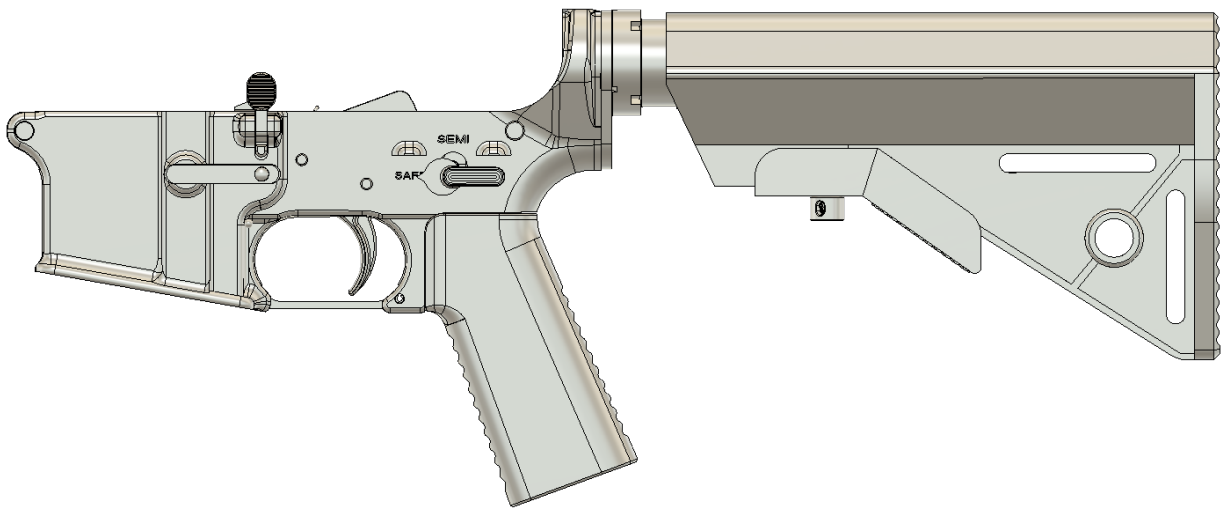

1. Operator Safety – Always ensure the weapon is “Unloaded” and “Safety ON”.
2. Remove the magazine, pull the charging handle and verify the chamber is empty to ensure the firearm is unloaded.

3. Push-in: Takedown Pin and Pivot pin first from the driver's side.  
Then,
4. Pull-out: Takedown Pin and Pivot Pin from the passenger side.
5. Remove: Upper Receiver from the Lower Receiver, set the Upper Receiver aside.
6. Loosen the grip screw from inside the pistol grip to allow the grip to drop about ½ inch. Be careful not to lose the safety detent or safety detent spring.

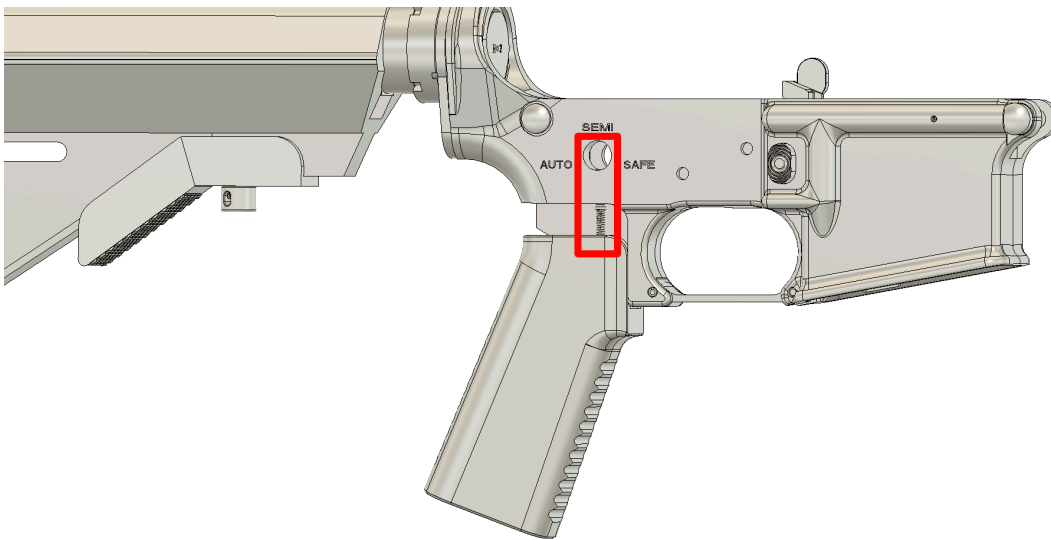

7. Remove the safety selector from the lower receiver.
8. Once the Safety is out, carefully de-cock the hammer.



10. Inspect and clean the FCG (Fire Control Group) pocket. Cock and then insert the Drop-in Trigger assembly into the FCG pocket.

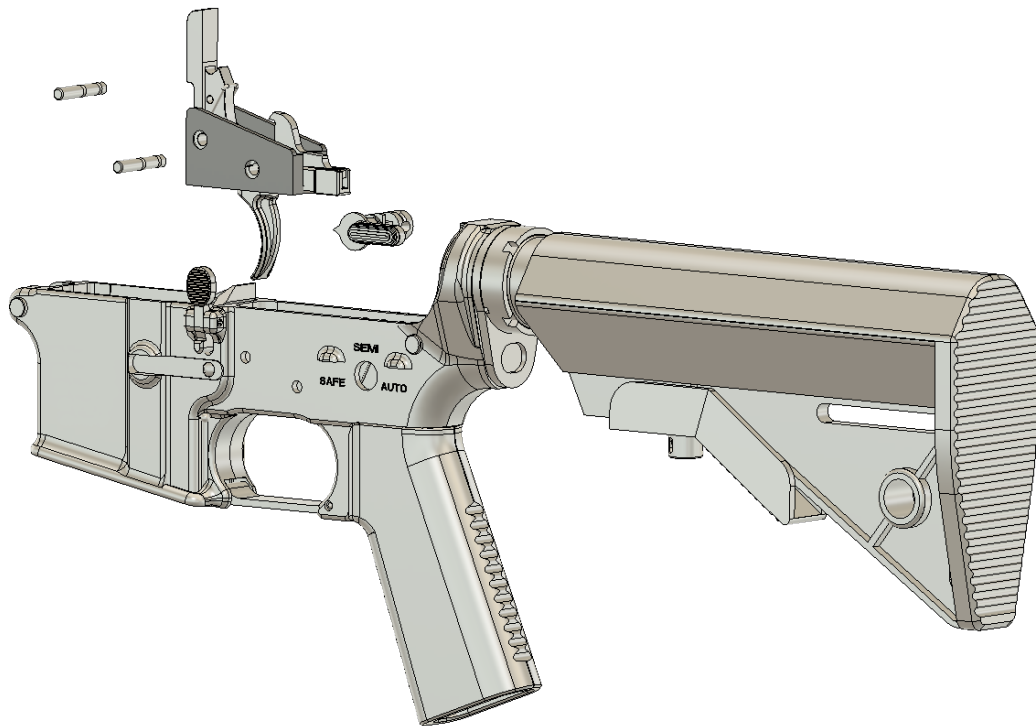

11. Install the hammer and trigger pin (anti-walk-pins, optional) from the driver to the passenger side.
12. Insert and re-seat the safety selector.
13. Re-Align the pistol grip, safety detent spring, and safety detent, then tighten the grip screw to the specs.

14. Use a small pointed tool to push both sides of the hammer spring toward the center, away from the set screw areas. Use the hex wrench, comes with the package, to tighten both set screws until seated.

**IMPORTANT:** Ensure both set screws are firmly snugged down. Do not over-tighten the set screws.

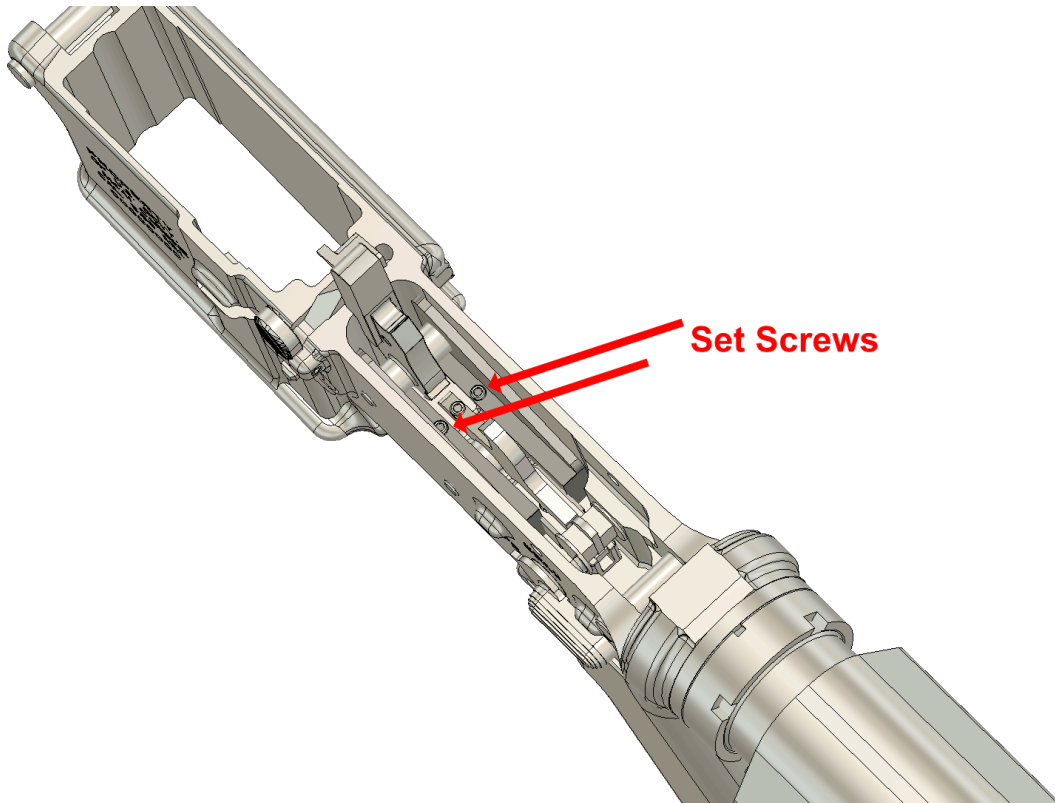

15. Function tests your new trigger to ensure it functions properly and works as it should. **STOP** if you experience any misfire or reset issues. Follow the troubleshooting procedures to diagnose the trigger issue.

**WARNING:**

**NEVER** load the ammunition into the firearm if the drop-in trigger has failed the function test.

## To adjust the trigger-pull weight:

Every Drop-in Trigger has been set to default pull weight of 3.5lbs which is the lower limit of this trigger set. **(THIS TRIGGER'S PULL WEIGHT IS DESIGNED BETWEEN 3.5LBS TO 5LBS. ANY ALTERATION OVER THE MINIMUM AND MAXIMUM LIMIT WILL RESULT MALFUNCTION).**

1. Carefully release the hammer if already cocked. Utilize the Allen wrench included in the package. Turn the set screw on top of the trigger assembly by  $\frac{1}{4}$  turn, counter-clockwise to decrease the trigger pull weight, or clockwise to increase the pull weight. Test your trigger, and repeat if necessary. Do not attempt to live fire the firearm without a complete function test.

### Caution:

Maximum **360 degrees** turn in each direction only. Do not loosen the set screw all the way out.

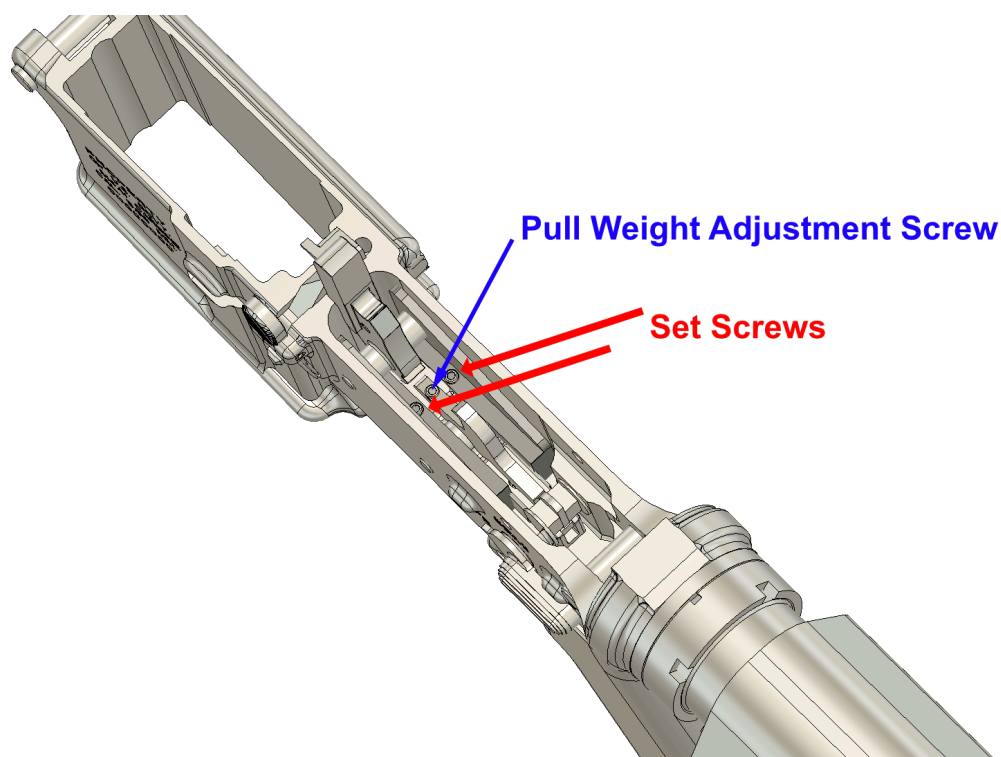

**Disclaimer:**

Installation, testing, and adjustment performed by a certified gunsmith is highly recommended.

**Note:**

Installation of aftermarket drop-in trigger may void all or part of your firearm manufacturer's warranty, so please check with the firearm manufacturer to find out if installation will affect your firearm warranty prior to installation of the trigger.

TO THE EXTENT ALLOWABLE BY APPLICABLE LAW. ALL LIABILITY FOR INCIDENTAL, PUNITIVE, SPECIAL, OR CONSEQUENTIAL DAMAGES ARE EXPRESSLY DISCLAIMED, TO THE EXTENT ALLOWABLE BY APPLICABLE LAW.

IBOR-USA does not assume any liability arising from loss of life, personal injury, and/or property damage in connection with the use, misuse, or modification of the IBOR-USA product, or the firearm in which the IBOR-USA Product is installed. Warranties are handled directly by IBOR-USA, not through our dealer network. To obtain warranty coverage, please contact us directly at the number/website below for a return authorization. The product alleged to be defective must be returned to IBOR-USA for inspection. The cost of shipping to us is the customer's responsibility. Any products determined by IBOR-USA to require warranty coverage will be replaced or repaired, at IBOR-USA's sole option